

Kurt Vise Milling Machine Stop  
Clamp

.750  
DIA. THRU

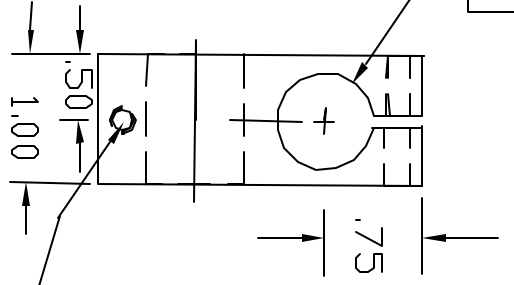

drill & tap 10-32 to slot.  
#7 drill far side

drill & tap 10-32 to slot.  
#7 drill far side

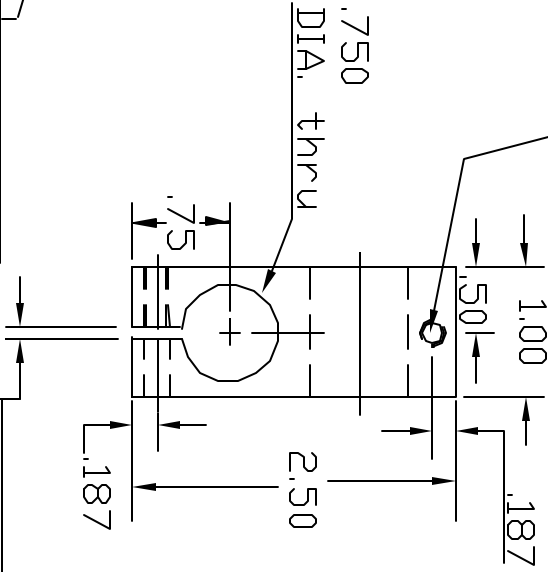

SLOT = .06 - .09  
WIDE  
TYPICAL

Tolerance chart  
.750 DIA. Holes = +.002/- .000  
.XX = +/- .01 .XXX = +/- .005

Drawn by S.P.C.  
Sept. 29, 2004

1 piece req'd.  
make from 1" sq. steel  
part 2 of 3